

FLUID COOLING | P-Bar Series Industrial AOL

Southwest Thermal Technology

Questions? Call Sales M-F 8am-5pm PT
p. 888-226-8522 | www.SouthwestThermal.com

BRAZED ALUMINUM CONSTRUCTION

HYDRAULIC OR COMPRESSOR OIL COOLING

Features

- Large Oil Flow
- High Performance
- Industrial Duty
- Brazed Aluminum Bar and Plate Core
- Compact all aluminum core assembly
- Ideal for converting water cooled equipment to air cooled
- Eliminates high water and sewer costs
- Eliminates corrosion problems associated with water cooled units
- Vertical air flow works well for heat recovery
- State-of-the-art heat transfer technology
- Hydraulic motors available
- Optional SAE Ports
- Marine corrosion control coatings available
- High performance air side fin design
- Detachable legs



AIR COOLED AOL

Ratings

Maximum Operating Pressure
250 psi (17 BAR)

Maximum Operating Temperature
300° F (150° C)

Materials

Legs Steel with baked enamel finish

Shroud Steel

Standard Core Brazed Aluminum Bar and Plate

- Tanks – 5052 Aluminum
- Nose Bar & Little Bar – 3003-H Aluminum
- Air Fin, Plate, Turbulator & End Plate – 3003-O Aluminum

Fan Aluminum Hub, Plastic Blades

Motor TEFC

Fluid Compatibility

Petroleum/mineral oils

Oil/water emulsion

Water/ethylene glycol

How to Order

AOL				
Model Series AOL - Standard	Model Size Selected 400 725 950 1200 1600 2000 2500 3000 3500	Connection Type Blank - NPT S - SAE	Specify Motor Required 0 - No Motor 2 - Single Phase 3 - Three Phase 6 - 575 Volt 9 - Hydraulic 18 - IEC Three Phase	Noise Level Blank - Standard Noise Level LN - Low Noise Level

Dimensions

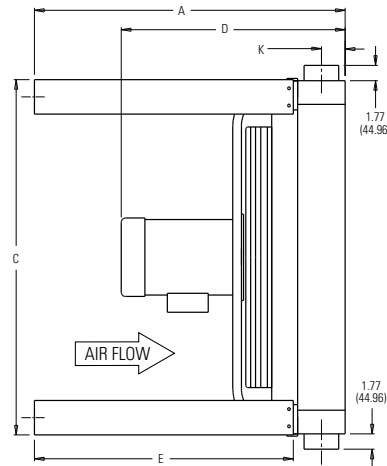
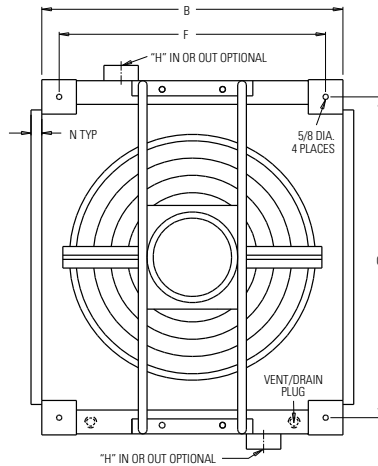

Model	A	B	C	D Approx.	E	F	G	H NPT	H SAE	J	K	L	Net Weight Lbs.	Shipping Weight Lbs.
AOL-400	34.20 (868.68)	17.96 (456.18)	22.69 (576.33)	20.86 (529.84)	30.00 (762.00)	13.96 (354.58)	18.69 (474.73)	2.00	#32 SAE 2-1/2-12 UN-2B	5.93 (150.62)	1.85 (46.99)	1.25 (31.75)	109 (49.44)	148 (67.13)
AOL-725	34.20 (868.68)	22.37 (568.20)	30.57 (776.48)	20.86 (529.84)	30.00 (762.00)	18.37 (466.60)	26.57 (674.88)	2.00		5.88 (149.35)	1.85 (46.99)	1.25 (31.75)	151 (68.49)	170 (77.11)
AOL-950	36.01 (914.65)	26.78 (680.21)	37.25 (946.15)	23.62 (599.95)	30.00 (762.00)	22.78 (578.61)	33.25 (844.55)	2.00		6.82 (173.23)	2.76 (70.10)	1.25 (31.75)	221 (100.24)	300 (136.08)
AOL-1200	36.01 (914.65)	26.78 (680.21)	41.20 (1046.48)	25.51 (647.95)	30.00 (762.00)	22.78 (578.61)	37.20 (944.88)	2.00		6.00 (152.40)	2.76 (70.10)	1.25 (31.75)	296 (134.26)	430 (195.04)
AOL-1600	36.01 (914.65)	34.89 (886.21)	41.20 (1046.48)	27.51 (698.75)	30.00 (762.00)	30.89 (784.61)	37.20 (944.88)	2.50	2-1/2 SAE 4 Bolt FLG	8.00 (203.20)	2.76 (70.10)	1.25 (31.75)	355 (161.03)	515 (233.60)
AOL-2000	36.01 (914.65)	37.88 (962.15)	51.05 (1296.67)	26.25 (666.75)	30.00 (762.00)	33.88 (860.55)	47.05 (1195.07)	2.50		8.00 (203.20)	2.76 (70.10)	1.25 (31.75)	482 (218.63)	582 (263.99)
AOL-2500	36.01 (914.65)	43.70 (1109.98)	49.08 (1246.63)	28.51 (724.15)	30.00 (762.00)	39.70 (1008.38)	45.08 (1145.03)	3.00	3" SAE 4 Bolt FLG.	8.00 (203.20)	2.76 (70.10)	1.25 (31.75)	555 (251.74)	655 (297.10)
AOL-3000	36.01 (914.65)	52.52 (1334.01)	51.05 (1296.95)	30.51 (774.95)	30.00 (762.00)	48.52 (1232.41)	47.05 (1206.50)	3.00		8.00 (203.20)	2.76 (70.10)	1.25 (31.75)	724 (328.40)	825 (374.21)
AOL-3500	36.01 (914.65)	56.30 (1430.02)	51.05 (1296.95)	30.51 (774.95)	30.00 (762.00)	52.30 (13328.42)	47.05 (1206.50)	3.00		8.00 (203.20)	2.76 (70.10)	1.25 (31.75)	760 (344.73)	860 (390.09)

Note: We reserve the right to make reasonable design changes without notice. All dimensions are in inches and (millimeters).

Selection Procedure

Performance Curves based on 100°F (55.56°C) E.T.D. or Entering Temperature Difference (E.T.D = Entering oil temperature minus ambient air temperature). SAE #10 oil @ 200°F (93.33°C).

Oil pressure drop coding:

- ✕ = 5 PSI (.345 BAR)
- = 10 PSI (.689 BAR)
- ◆ = 15 PSI (1.03 BAR)
- ▲ = 20 PSI (1.38 BAR)
- = 30 PSI (2.10 BAR)

E.T.D. temperature correction formula:

ENGLISH Version

$$HP_{Curve} = HP_{To Be Removed} \times \frac{100}{Desired E.T.D.}$$

METRIC Version

$$\frac{KW}{^{\circ}C} = \frac{Heatload (KW)}{Desired E.T.D. (^{\circ}C)}$$

Conversion

$$Hp = \frac{KW}{^{\circ}C} = X .745 \times E.T.D. (^{\circ}F)$$

Notes

- A three-way thermostatic valve is recommended to bypass the cold oil around the heat exchanger during start up.
- Support piping as needed. Flexible connectors must be properly installed to validate warranty.
- Coolers should not operate in ambient temperatures below 35°F (1°C). Consult factory for recommendations.
- The fan cannot be cycled.
- AOL coolers operated outdoors must be protected from weather. Consult factory for recommendations.
- If duct work or additional static resistance is added to the cooler airstream, an auxiliary air mover may be required.
- Can be mounted for horizontal air flow, with oil in at bottom port.

Maintenance

Periodic cleaning of the fins with compressed air is needed to remove the accumulation of dirt and dust. If the inside of the tubes need to be cleaned of oil and carbon, use a chlorinated solvent. Do not use strong solvents. Do not use acids or caustic cleaners.

Specifications

Electric Motor & Fan Data⁽¹⁾ (60 Hz Nema Frame)

Model	Fan CMM	Fan CFM	Motor H.P.	Voltage	Phase	Full Load Amps 230V	Frequency (Hz)	RPM	Nema Frame	Thermal Overload	Sound dB(A) at 3 ft.
AOL-400	62.30	2200	1.0	115/208-230	1	6.0	60 ⁽²⁾	3450	56C	No	97
	51.68/62.30	1825/2200	1.0	208-230/460 ⁽³⁾	3	3.6/3.2	50/60	2850/3450	56C	No	97
AOL-725	101.94	3600	1.5	115/208-230	1	8.5	60 ⁽²⁾	3450	56C	No	100
	84.95/102.94	3000/3600	1.5	208-230/460 ⁽⁴⁾	3	4.8/4.2	50/60	2850/3450	56C	No	100
AOL-950	133.09	4700	1.5	115/208-230	1	8.6	60 ⁽²⁾	1740	145TC	No	92
	133.09	4700	1.5	208-230/460	3	4.6	60 ⁽²⁾	1740	145TC	No	92
AOL-1200	198.22	7000	5.0	230	1	23.00	60 ⁽²⁾	1740	184TC	No	94
	198.22	7000	3.0	208-230/460	3	8.8	60 ⁽²⁾	1740	182TC	No	96
AOL-1600	223.70	7900	5.0	208-230/460	3	13.4	60 ⁽²⁾	1740	184TC	No	98
AOL-2000	311.49	14000	7.5	230/460	3	19.6	60 ⁽²⁾	1740	213TC	No	98
AOL-2500	396.44	14000	7.5	230/460	3	19.6	60 ⁽²⁾	1740	213TC	No	98
AOL-3000	495.54	17500	10.0	230/460	3	24.8	60 ⁽²⁾	1740	215TC	No	102
AOL-3500	495.54	17500	10.0	230/460	3	24.8	60 ⁽²⁾	1740	215TC	No	102

⁽¹⁾ Published electrical ratings are approximate, and may vary because of motor brand. Actual ratings are on motor nameplate.

⁽²⁾ May also be operated at 50 hz. Consult factory for details.

⁽³⁾ 50 Hz voltage: 190-200-208-220/380-400-415-440

⁽⁴⁾ 50 Hz voltage: 190-208/380-415

All motors shown are TEFC—Other motor options available upon request.

Electric Motor Information (50 Hz IEC Frame)

Model	CMM	CFM	KW	Voltage	Phase	Frequency	RPM	Frame	Sound dB(A) at 1 meter
AOL-400	52.4	1850	.75	220/240/380/415	3	50 Hz	3000	80	81
AOL-725	85.0	3001	1.10	220/240/380/415	3	50 Hz	3000	80	80
AOL-950	108.2	3821	1.50	220/240/380/415	3	50 Hz	1500	90	78
AOL-1200	165.1	5834	2.20	220/240/380/415	3	50 Hz	1500	100	83
AOL-1600	186.4	6584	3.00	220/240/380/415	3	50 Hz	1500	100	85
AOL-2000	331.3	11700	4.00	220/240/380/415	3	50 Hz	1500	112	88
AOL-2500	331.3	11700	4.00	220/240/380/415	3	50 Hz	1500	112	88
AOL-3000	410.6	14500	7.50	220/240/380/415	3	50 Hz	1500	132	90
AOL-3500	410.6	14500	7.50	220/240/380/415	3	50 Hz	1500	132	90

All IEC frame motors have CE mark.

Electric Motor Information (AOL-Low Noise)

Model	HP	Nema Frame	LN RPM	LN CFM	LN CMM	Voltage	Frequency (Hz)	Sound dB(A) at 3 ft.
AOL-400-1PH-LN	1	56C	1725	1100	31.15	115/230	60	72
AOL-400-3PH-LN	1	56C	1725	1100	31.15	230/460	60	72
AOL-725-1PH-LN	1.50	56C	1725	1780	50.40	115/230	60	82
AOL-725-3PH-LN	1.50	56C	1725	1780	50.40	230/460	60	82
AOL-950-3PH-LN	1.50	145TC	1160	3150	89.20	230/460	60	76
AOL-1200-3PH-LN	1.50	182TC	1160	4690	132.81	230/460	60	75
AOL-1600-3PH-LN	2	184TC	1160	6510	184.34	230/460	60	78
AOL-2000-3PH-LN	5	213TC	1160	8700	246.36	230/460	60	85
AOL-2500-3PH-LN	5	213TC	1160	11700	331.31	230/460	60	85
AOL-3000-3PH-LN	5	215TC	1160	13500	382.28	230/460	60	93
AOL-3500-3PH-LN*	10	254UC	1160	16200	458.73	230/460	60	91

Available in 60 Hz Nema Frame only.

Hydraulic Motor Information

Model	Oil Flow Required GPM (LPM)	Min. Pressure Required PSI (BAR)	Motor IN ³ /REV (CM ³ /REV) Displacement	Sound dB(A) at 3 ft.
AOL-400	3.3 (12.49)	425 (29.31)	0.22 (3.6)	97
AOL-725	3.3 (12.49)	675 (46.54)	0.22 (3.6)	100
AOL-950	10.1 (38.23)	300 (20.68)	1.4 (22.94)	92
AOL-1200	10.1 (38.23)	700 (48.26)	1.4 (22.94)	94
AOL-1600	10.1 (38.23)	1100 (75.84)	1.4 (22.94)	98
AOL-2000	10.1 (38.23)	1650 (113.76)	1.4 (22.94)	98
AOL-2500	10.1 (38.23)	1650 (113.76)	1.4 (22.94)	98
AOL-3000	10.1 (38.23)	2000 (137.90)	1.4 (22.94)	102
AOL-3500	10.1 (38.23)	2000 (137.90)	1.4 (22.94)	102

Notes: Maximum Pressure is 2000 psi. Stated Minimum Operating Pressure is at Inlet Port of Motor. 1000 psi Allowable Back Pressure.

Performance Curves

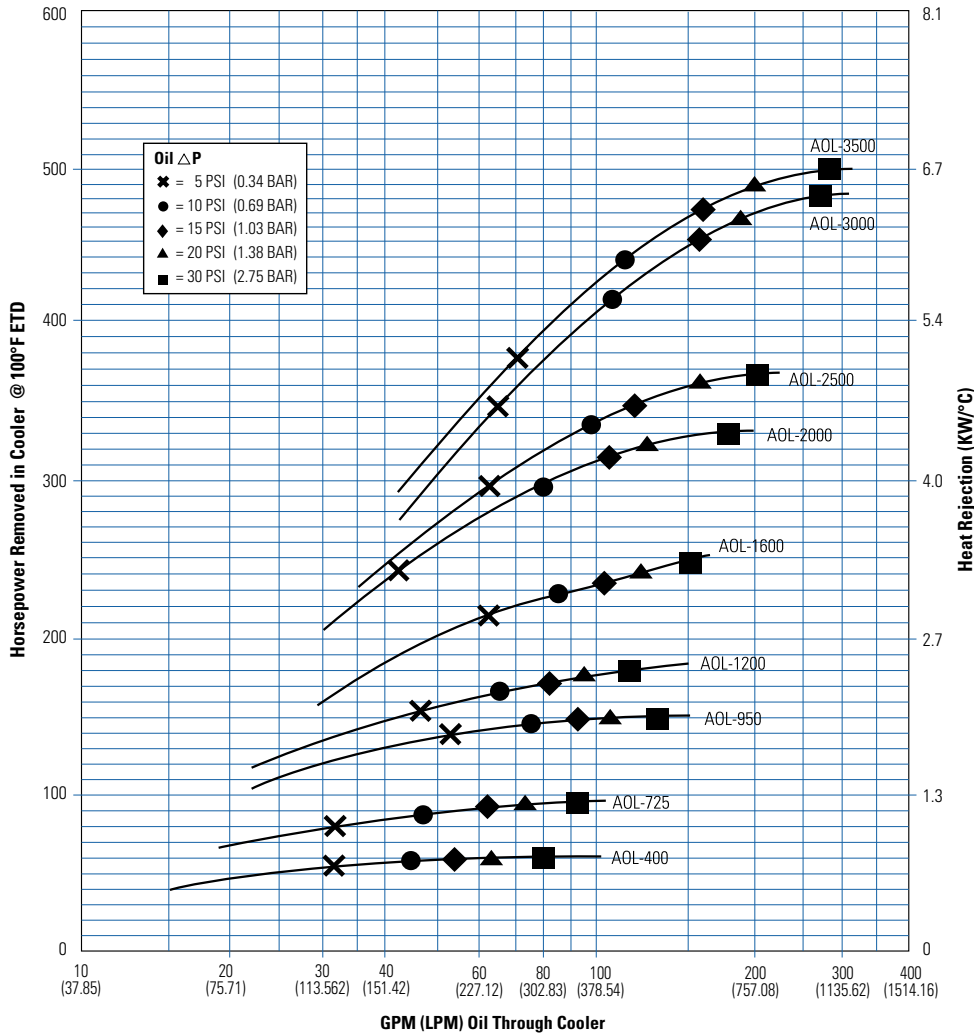

Note: Derate heat rejection values 15% if using 50Hz motors.

Low Noise Option

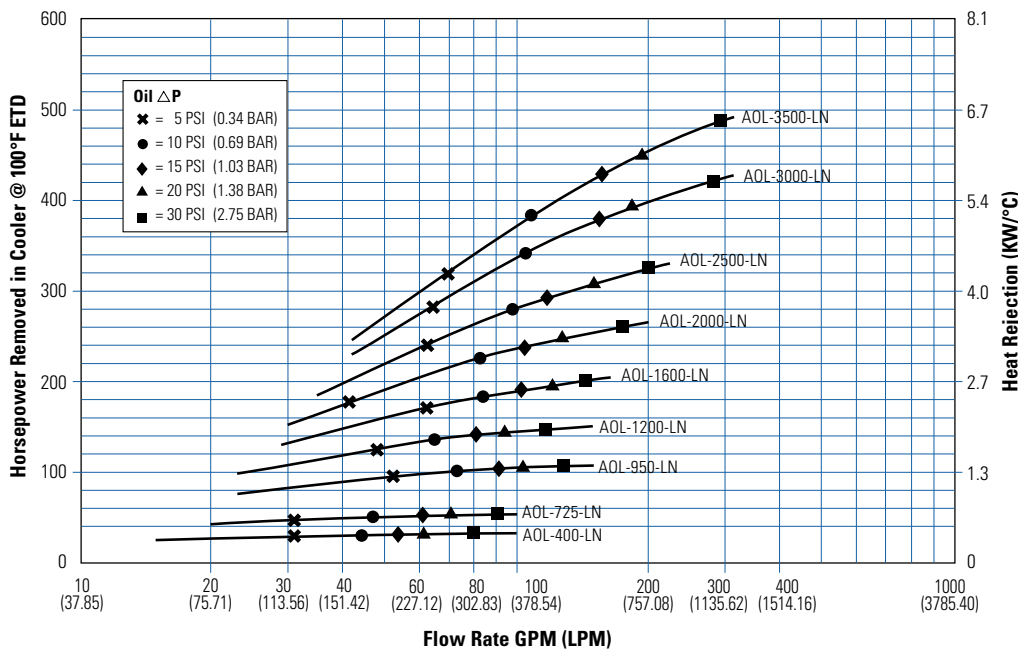

Available in 60 Hz Nema Frame only.

